

VistaVox S and VistaVox S Ceph 3D from Dürr Dental

3D, 2D and cephalometric projections images with exceptional image quality



Taking diagnostics to the next level

VistaVox S combines diagnostic reliability with efficiency and lower radiation doses



This is what counts:

- Ideal 3D imaging volume matched to the jaw arch (Ø 130 x 85 mm)
- Ø 130 x 50 mm volumes for single images of the upper and lower jaw
- Ø 50 x 50 mm volumes in 80 or 120 µm resolution
- Excellent image quality in 2D and 3D thanks to the high-resolution CsI sensor with a pixel size of 49.5 µm
- Reduced radiation dose thanks to the anatomically adapted volume
- VistaSoft – modern, ergonomic image processing software

Ideal imaging volume, easy positioning, high image quality: VistaVox S represents a milestone in the field of 3D X-ray systems. Thanks to its unique technology, the 3D images generated with this system cover everything you need for reliable diagnoses, well-founded treatment decisions and convincing patient communication. In addition, the S-Pan technology of VistaVox S also enables pinpoint-accurate OPG image acquisitions in superior Dürr Dental quality. Thanks to a high-resolution CsI sensor with a pixel size of 49.5 µm, you can benefit from exceptional image quality – both in 3D and in 2D. All of these things make VistaVox S not only a highly efficient solution for dentistry, but also a safe investment.



3D diagnostics: the key indications

With VistaVox S 3D images you can increase diagnostic reliability and enable accurate treatment planning. The key indications at a glance:

Tooth development	Hyperplasia or dysplasia Retained or impacted teeth
Fractures	Root or jaw fractures
Implant technology	Augmentation/bone formation For planning In the event of complications
Endodontics	Periapical examinations Complex anomalies of the root canal system Fractured root canal instruments within the root canal
Foreign bodies	Suspected perforation, in particular pin perforation Localisation of foreign bodies in the mouth and jaw area
Salivary stones	Localisation of salivary stones
Pathological changes	Maxillary sinus area Jawbone Cysts, tumours, osteonecrosis

See what you need to see

VistaVox S offers an ideal 3D volume that is adapted to the shape of the jaw

Almost universal fit

The jaw-shaped field of view of the VistaVox S shows an area of \varnothing 130 x 85 mm volume that is relevant for diagnostics and is thus visibly larger than many common volumes. The advantage of this is that by changing the volume shape, VistaVox S also shows the rear molar area in full – an essential requirement for diagnosing an impacted wisdom tooth, for example. The special feature of VistaVox S is that its imaging volume is based on the human anatomy, representing precisely the region you need covered for diagnostics in the dental region.

The two additional volume sizes, \varnothing 130 x 50 mm upper jaw and \varnothing 130 x 50 mm lower jaw, ensure flexibility in day-to-day work in the practice and allow you to display the two jaws separately.

The ideal jaw-shaped volume is achieved with the aid of a special curved path with 540° rotation, for which the VistaVox S requires just 18 seconds. In conjunction with a tightly collimated conical beam and the highly sensitive CsI sensor, this path allows the radiation dose to be kept particularly low. The VistaVox S reconstruction algorithms allow the 3D volume to be displayed in the shortest possible time.

1,020 patients were examined in a study from Dr Johannes Krause. The study shows that a volume with a height of 85 mm and diameter of 110 mm is required for 100% coverage of the dental region. With a volume of e.g. \varnothing 80 x 80 mm, only around 1.4% of all patients can be covered in full. By contrast, the adapted, jaw-shaped volume of the VistaVox S covers the dental region of all patients.*

Additional volumes \varnothing 50 x 50 mm

In addition to jaw-shaped images and the two additional volume sizes for the upper and lower jaw, VistaVox S offers ten further \varnothing 50 x 50 mm volumes: five each for the upper jaw and for the lower jaw. These are used if the Indication only requires imaging of a certain region of the jaw, e.g. for endodontical or implantological treatments. Depending on the required level of detail in the image, the volumes can be used with a resolution of either 80 or 120 μ m.

SQ mode

The SQ mode (Standard Quality mode) offers a further option for reducing the radiation dose. In this setting, the dose is reduced by 62% in comparison to HQ mode (Highest Quality mode). SQ mode can be used e.g. for implant planning, determination of the apical bone supply, for investigation of the sinuses or for the localisation of impacted or excess teeth. SQ mode can be used in all programs.

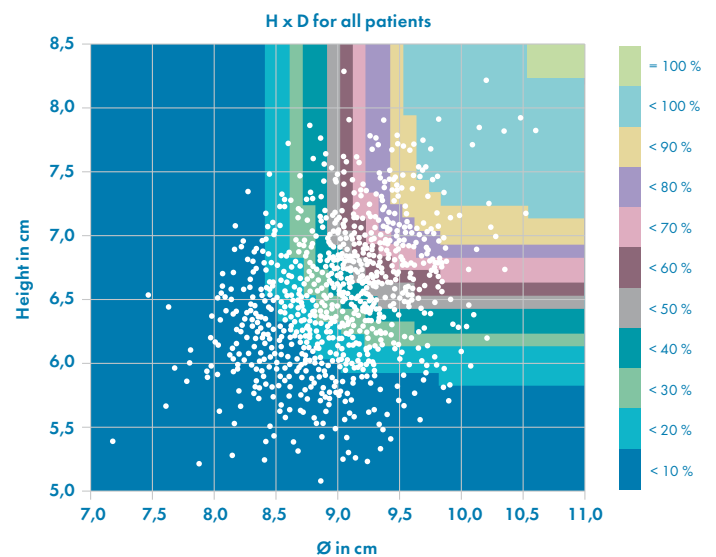

* Source and graphic bottom right: Dissertation conclusions, Dr Johannes Krause, "Investigations into the required field of view for imaging 3D diagnostics in dental medicine", 1 January 2013

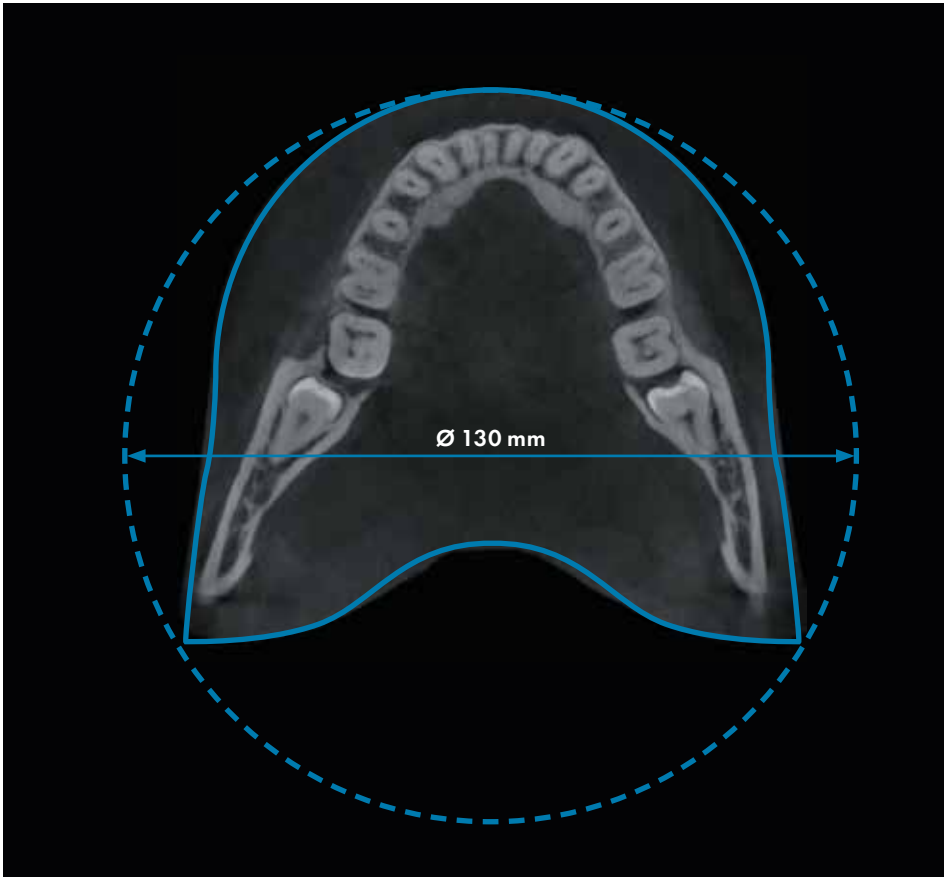

The jaw-shaped volume displays the region of a Ø 130 volume that is relevant for the diagnosis.

FOV Ø 130 x 85 mm



FOV Ø 130 x 50 mm



FOV Ø 130 x 50 mm, sinus

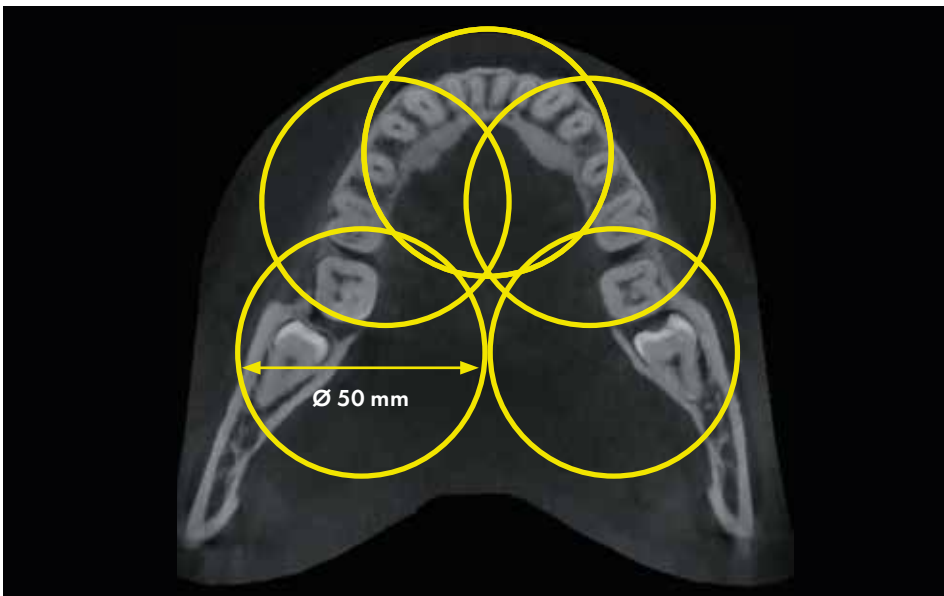

In addition to jaw-shaped images, VistaVox S offers ten further Ø 50 x 50 mm volumes: five each for the upper jaw and for the lower jaw.

FOV Ø 50 x 50 mm



2D images with exceptional image quality



VistaVox S offers not only excellent value for money, but will also help you and your surgery team to increase your flexibility. In addition to CBCT images, you can also use VistaVox S to generate brilliant OPGs, which set new standards in the image sharpness of extraoral images. Thanks to this versatility, the new VistaVox S will really add value to your surgery. The unit also raises the bar in terms of efficiency. It enables the scan of a complete OPG image in a very short time of just seven seconds with an exceptionally low radiation dose. This will save you valuable time – not only in comparison to conventional X-ray solutions.

This is what counts:

- S-Pan technology for easier diagnostics
- CsI sensor for improved image quality and reduced radiation exposure
- Extremely fast: OPG images from 7 seconds
- Tolerant of typical positioning errors – thanks to the S-Pan technology

Panoramic X-ray programs

With a total of 17 X-ray programs, you are well equipped for every diagnostic requirement. In addition to the standard panoramic program, VistaVox S also offers:

- Half-side recordings of right, left and front
- 4 child programs*: an acquisition mode with a smaller exposure area and a 45–56% reduction in the dose without any loss of diagnostic information
- 5 programs for orthogonal X-ray images
- 2 programs for temporomandibular imaging (functional diagnosis)
- 2 programs for sinus X-ray images to display paranasal sinuses

*Programs for children: for children and adolescents from the age of 7.

S-Pan technology



Reliable diagnoses thanks to incredibly sharp images

With S-Pan technology, the image regions that best correspond to the actual patient anatomy are automatically selected from a large number of parallel layers. These image parts are merged to form a panoramic image, which focuses on the actual anatomy of the patient. Deviations from the “average dentition” are taken into account, as are individually-angled teeth. The result is an image of impressive clarity, in which you will be able to immediately and effortlessly locate all anatomically relevant structures. Since the reconstruction is aligned to the actual position of the bite, incorrect positioning is compensated for to a certain extent. This saves time for the surgery and prevents the patient from having to have repeat images taken.

VistaVox S Ceph: exemplary ergonomics and efficiency

Time-saving Cephalometric exposure with a low X-ray dose

Short scan time and high image quality with a low X-ray dose

The very short scan time of just 1.9 seconds helps to avoid motion artefacts and to reduce the radiation dose. The modern high-sensitivity CsI sensors enable excellent image quality.

3-in-1 X-ray system

In addition to the various CBCT volumes and the 17 panoramic programs, VistaVox S Ceph also offers six modes for all types of cephalometric exposures:

- Head Lateral
- Head Full Lateral
- Head PA
- SMV (submentovertex)
- Waters View
- Hand



Head Lateral L



Head PA



SMV (submentovertex)



Waters View



Hand (Carpus)

Saving you time and money

VistaVox S Ceph is equipped with two high-end CsI sensors. The advantage: there is no need for the cumbersome process of unplugging and reconnecting between the 3D X-ray unit and the Ceph boom. To start a Ceph X-ray image acquisition, all you need to do is select the corresponding program mode.



Intuitive, efficient and easy to use

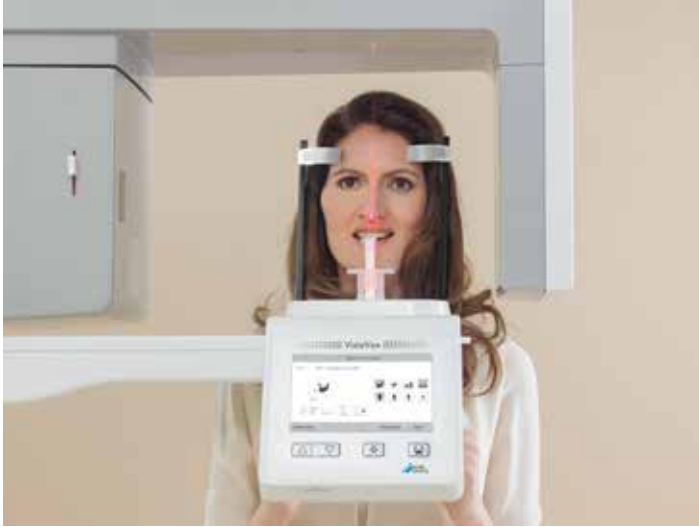

Simple and efficient patient positioning

Three alignment lights (sagittal, Frankfurt plane and Canine) for 2D X-ray images and two alignment lights (sagittal and Frankfurt plane) for 3D images make positioning a pleasant, easy and efficient task.



The display: all of the functions at a glance

The innovative 7" touch-display of the VistaVox S guides the operator reliably and clearly through the necessary steps. Handling and navigation are exceptionally intuitive, ensuring that the process of taking X-rays is as smooth and easy as possible.



Comfort bite: The basis for sharp images

With the Comfort Bite, VistaVox S offers an even more stable fixation of the patient, which additionally reduces movement during the exposure.

Thanks to its wider and softer support, it enables more comfortable positioning and is also ideal for edentulous patients.

Digitalisation of plaster casts and drill templates

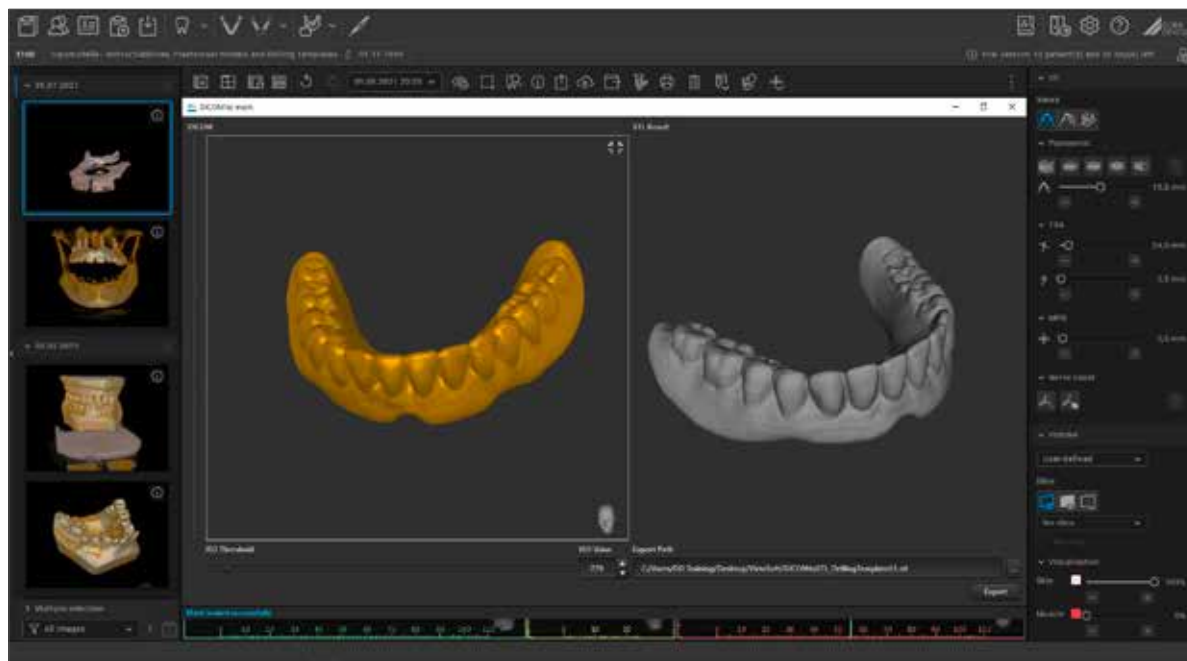

Plaster casts and drill templates can be digitalised with the aid of the optional model holder for VistaVox S. The VistaSoft tool “DICOM-to-STL” then converts the data to open source STL files for use e.g. In VistaSoft Implant & Guide for planning purposes or so that the data can be printed out with the aid of a 3D printer. Both the scans and the STL files are saved together with the relevant patient to ensure that you have access to all image data at all times.

VistaVox S 3D metal artefact reduction (MAR)

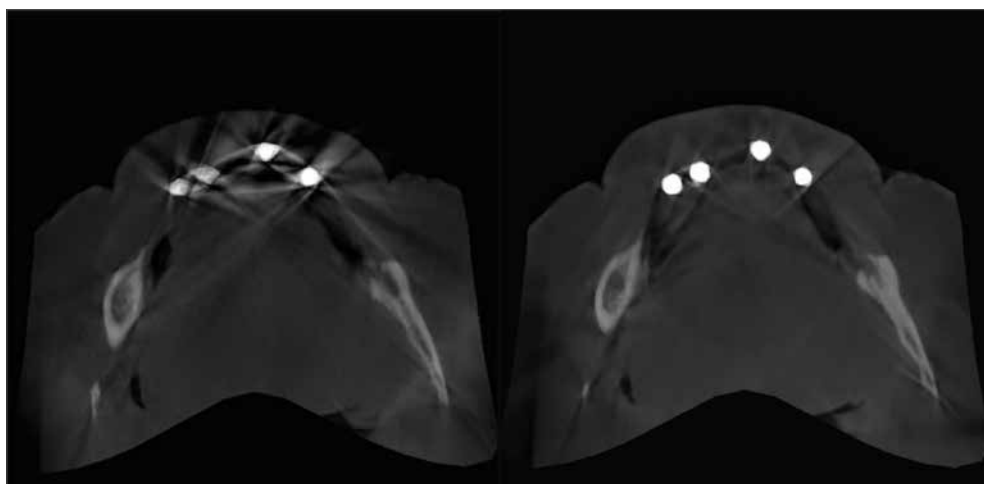

Metal artefacts are a real challenge for 3D imaging. In the three-dimensional reconstruction, radiopaque objects generate shadows (areas that are displayed completely white) and streaks. Particularly on patients with metal prosthetics, these artefacts make diagnostic work much more difficult. VistaVox MAR eliminates these metal artefacts automatically with the aid of state-of-the-art algorithms and is able to present anatomical structures much better as a result.

VistaSoft: simple workflow, intuitive working

VistaSoft is a particularly comfortable and efficient solution for the capture, editing and display of digital 2D and 3D X-ray images.



VistaSoft is intuitive to operate and opens up additional options for reliable diagnostics. Images can be edited using digital filters that adjust the contrast and sharpness of the X-ray image to assist the diagnosis. The network-capable software supports the export of DICOM data as well as various interfaces to all standard practice management software. The new design of VistaSoft has been optimised for professional diagnostics so that it offers you the best possible support. Thanks to the one-click principle, the software is quick and easy to operate – all the functions you need on a daily basis are just a single mouse click away. This will make your work faster than ever before.

Easy image comparisons on the light table

VistaSoft enables the reproduction of video, X-ray and 3D images on a shared digital light table. This allows you to consult images from different sources in your diagnostics. All 3D views can be rotated and tilted for optimum alignment. With the aid of a "navigation head", which always displays the current position, orientation is very simple in the different views.

All notes created in each layer can be quickly located with the aid of a list: with just one click, the view will jump to the corresponding layer, dispensing with the need for laborious searches.

Automated panoramic reconstruction is just one click away

The rendered OPG view makes it easier to navigate in the 3D volume. The panoramic curve required for this is automatically positioned by VistaSoft. A slider is used to select the required layer thickness.

VistaSoft is network capable and compatible with all current X-ray, scanner and camera systems from Dürre Dental. Thanks to VistaSoft MobileConnect and the optional "Imaging App", the image data can be called up at any time on an iPad.

VistaSoft – key features:

- One-click principle – All main functions are only a mouse click away
- Self-explanatory icons for intuitive handling
- Ergonomic design with simple and well thought-out workflows for efficient operation
- Modern saving concept – changes are saved automatically
- Easy to draw the nerve channel into the image
- Implant and drill template planning

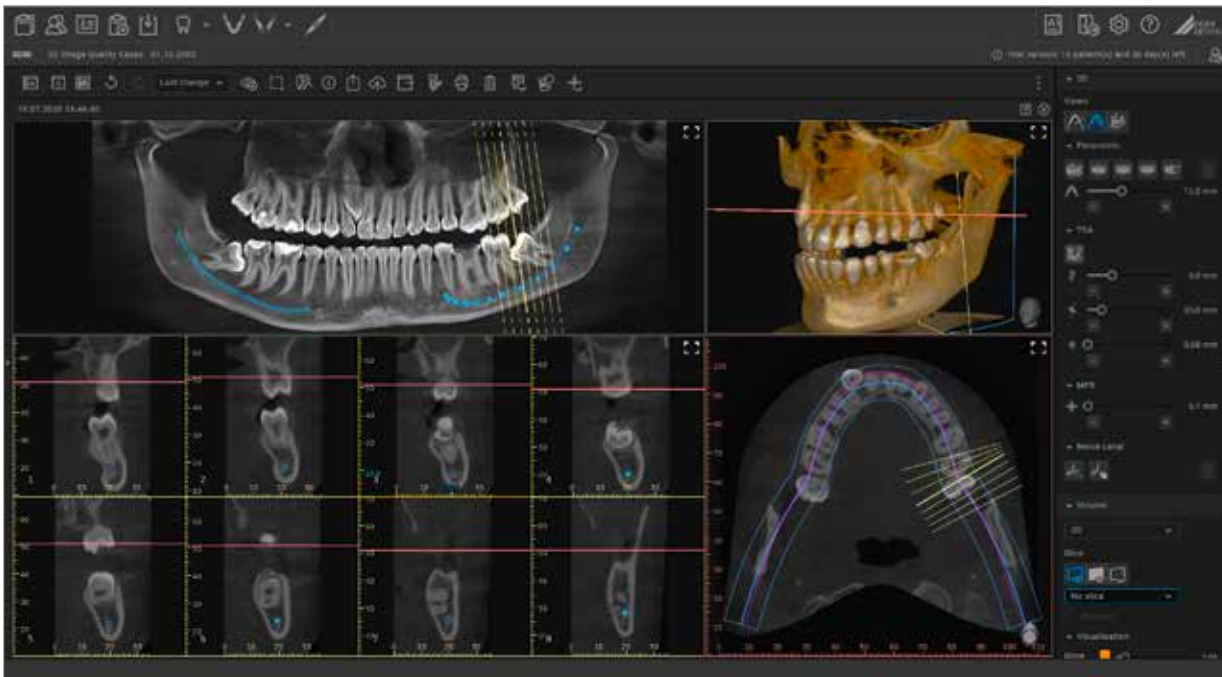

With VistaSoft and its AI-assisted algorithms you can easily display the automatically calculated mandibular canal and check its correct course via the transversal layer images (TSA view).

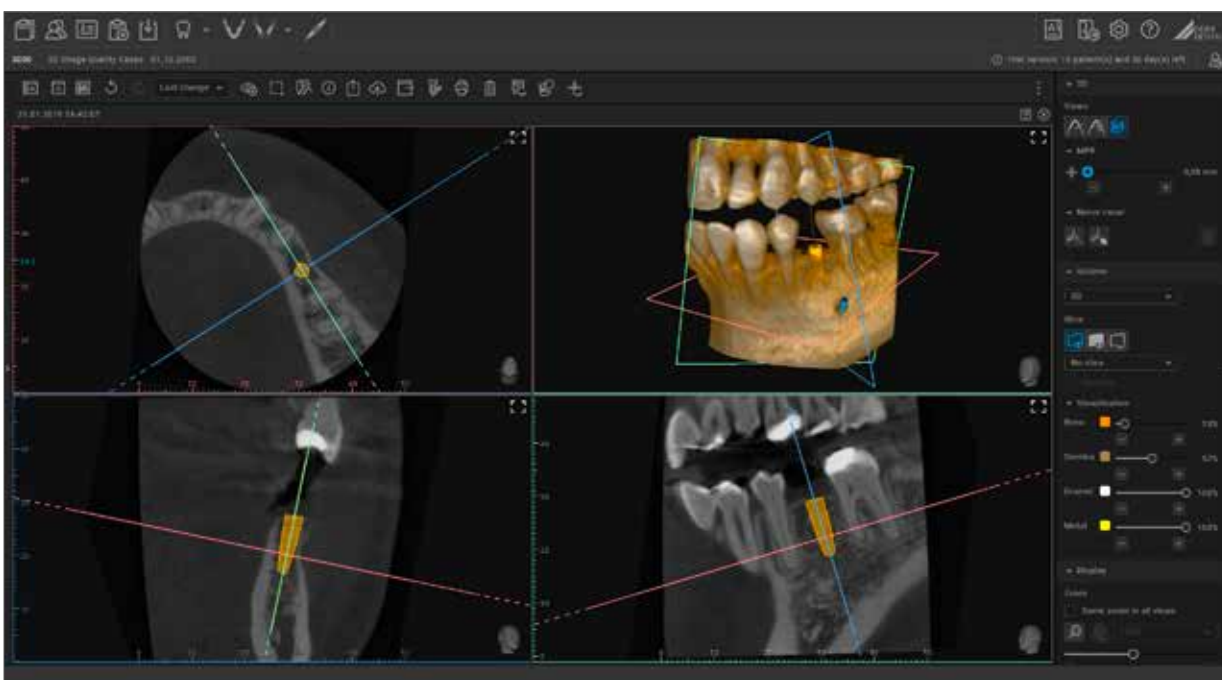

Implant planning with a 5 x 5 volume image. Shown here in the MPR view.

VistaSoft AI included

With the VistaSoft package you will gain access to powerful AI features that will not only make your day-to-day work in the practice noticeably more effective, but will also significantly increase the reliability of diagnostic work ahead of complicated procedures.

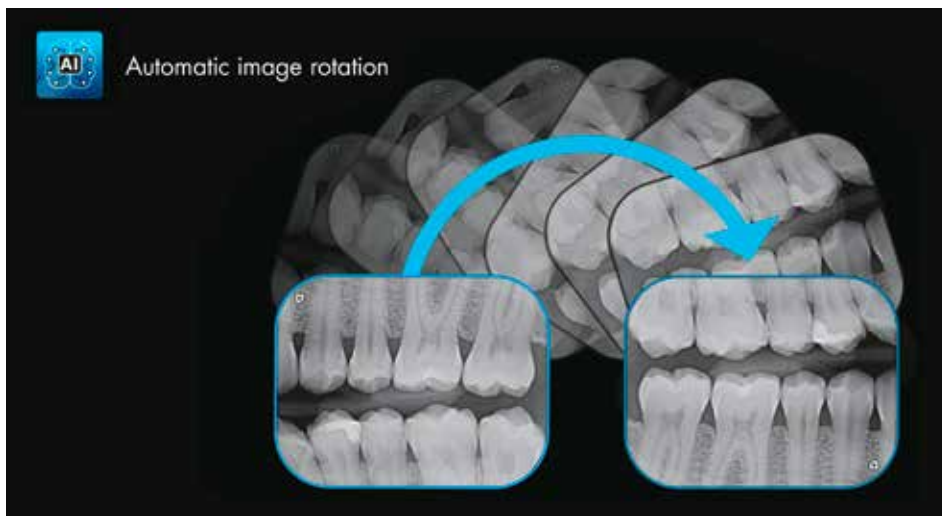

Automatic image rotation

The imaging software uses an algorithm based on artificial intelligence to check the orientation of intraoral X-ray images with the aid of anatomical features shown and corrects the rotation of the image automatically if needed. This will save you valuable time.



VistaSoft Trace

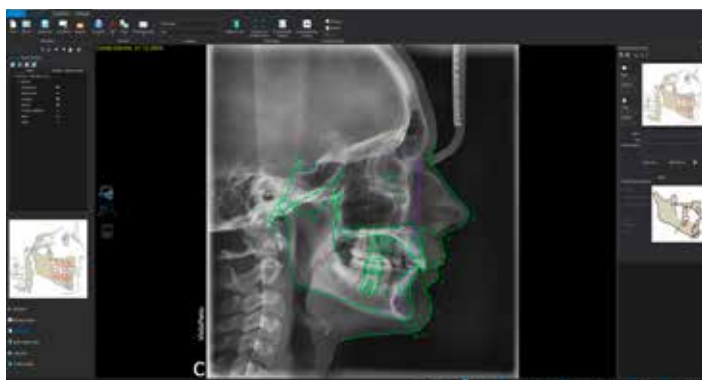

With the aid of innovative and extensive tools using artificial intelligence, cephalometric analyses can be completed within a few seconds using VistaSoft Trace. This user-friendly software add-on identifies reference points and soft tissue silhouettes automatically and plots them on the X-ray image. With VistaSoft Trace, images can be easily overlaid from various stages of the treatment so that progress can be monitored. In addition, the software also offers the option of simulating and displaying treatments based on planning data. In this way, the potential success of a course of treatment can be illustrated even before work gets under way.

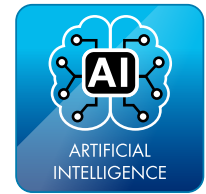

AI-assisted marking of the nerve canal

The AI-assisted mandibular canal detection system automatically calculates the position of the nerve canal in three-dimensional X-ray images. On this basis the diagnostician merely needs to check the proposed position.

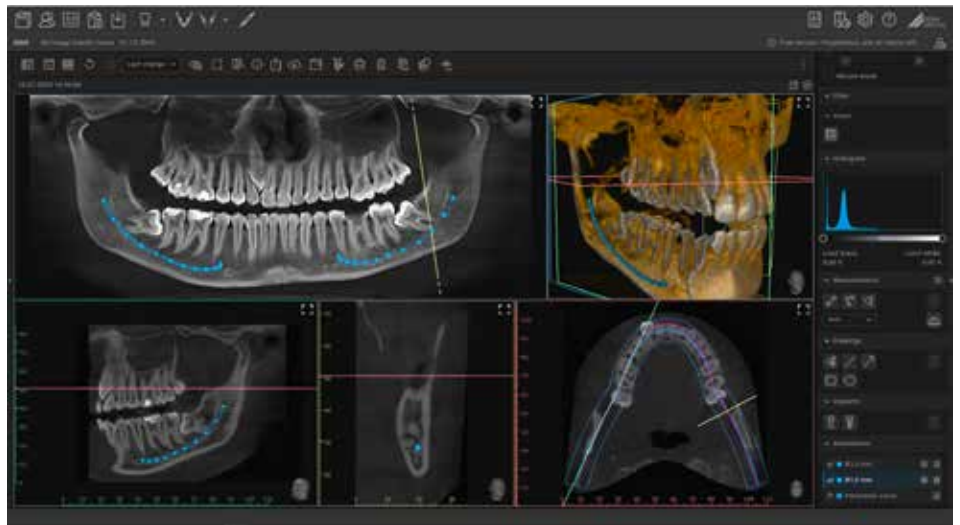

Panoramic display – AI-assisted

On 3D images, VistaSoft uses intelligent algorithms to adapt the calculated panoramic view to the anatomy of the patient. This displays a significantly improved OPG image, which shows the anatomy of the patient much more clearly.

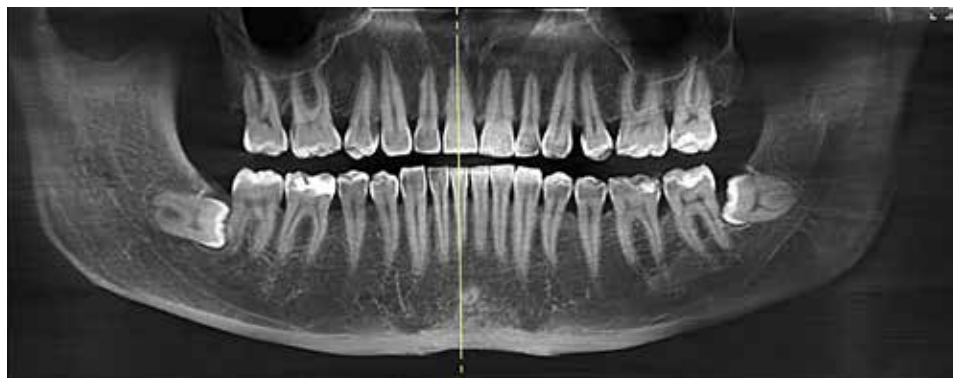

VistaSoft Implant: user-friendly 3D implant planning

With VistaSoft, among its many other functions your practice has access to a state-of-the-art tool for complete pre-surgical implant planning. With the new VistaSoft Implant module you can map the entire digital workflow.

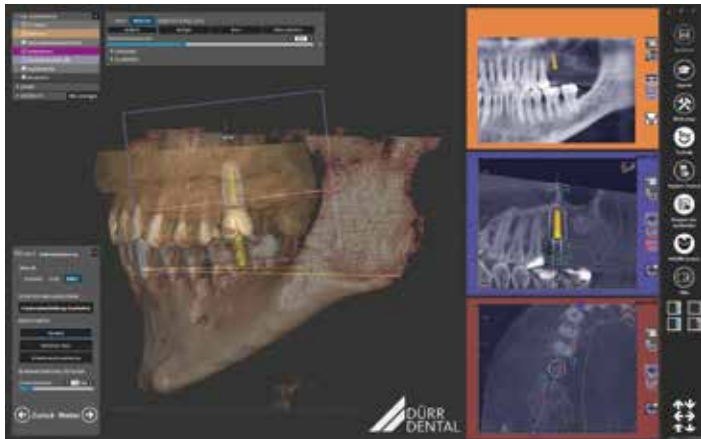

Easy and reliable implant planning

In VistaSoft Implant you can carry out the entire backward planning – from the crown to the actual implant – within a completely guided workflow, allowing you to plan simply and reliably. The data generated here can then be exported as an open source STL file and shared with other steps in the process.

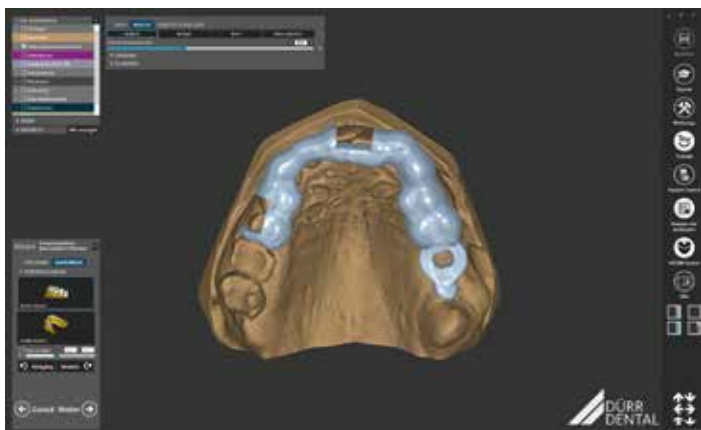

Simple design of drill templates

VistaSoft Guide will guide you reliably and comfortably through the planning of your drill template. A guided workflow ensures intuitive handling in the process, keeping your work fast and efficient at all times. The drill template data is then saved in an open source STL format and can be forwarded directly to the laboratory or to a 3D printer.

VistaSoft Implant & Guide – key features:

- Reliable and efficient implant planning
- Simple matching of optical scan data and 3D data
- Easy planning thanks to the guided workflow
- Planning of drill templates
- Straightforward exchange of data thanks to the open source STL files

Digital implant workflow with VistaSoft and SICAT

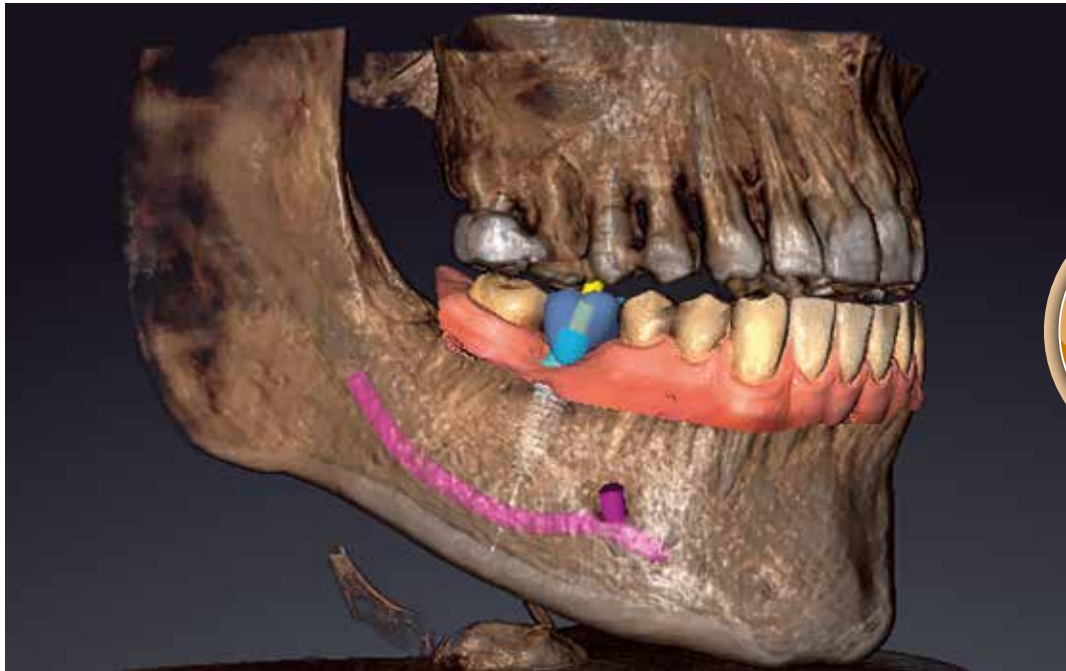

Now also available with SICAT Endo!

Implant planning – simple and intuitive

Through its cooperation with SICAT, Dürr Dental has been able to stay faithful to its philosophy of helping dental practices prepare themselves for the future with improved workflows in their day-to-day operations. Customers of both companies benefit, because CEREC-based implant planning data can now also be produced with Dürr Dental X-ray units. For more than a decade, SICAT has supplied application-oriented applications with innovative solutions for many specialist areas of digital dentistry. With SICAT Implant 2.0 your implant planning is now even easier and faster. You can order SICAT drill templates directly from the software to put your implant plans straight into practice with the world's only solution for CEREC Guide planning.

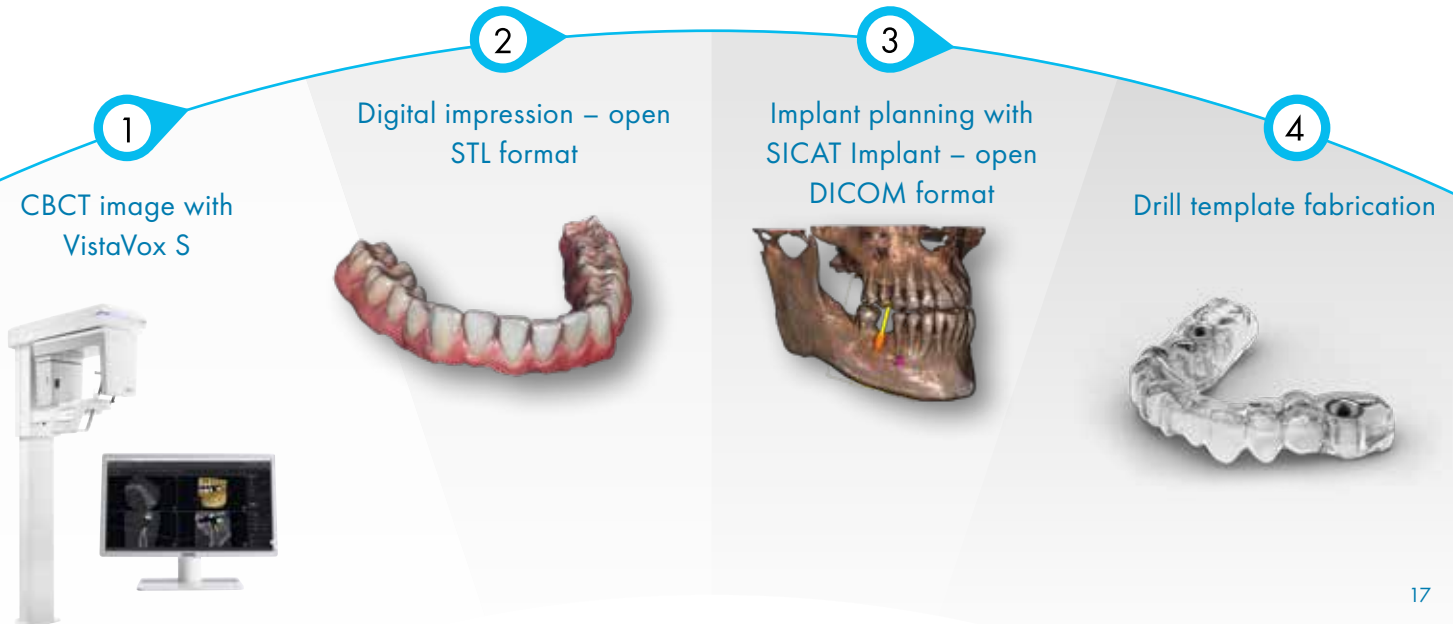

Facts and figures at a glance

VistaVox S

X-ray HV generator

Voltage, current	50–99 kV, 4–16 mA
Rated power	1.6 kW

Tube

Focal point	0.5 mm (IEC60336)
Total filtration	2.8 mm AL

Image detector

Type	CsI CMOS photodiode array
Pixel size	49.5 μ m
Active sensor surface area	135.8 x 36.4 mm

Scan times

Scan times	From 2 to 18 secs.
------------	--------------------

Panorama programs

Panoramic image acquisition programs	17
Image acquisition programs for children*	4

Magnification factor

2D images	1.26
-----------	------

3D volume

- Ø 130 x 50 mm upper/lower/sinus
- Ø 130 x 85 mm diagnostic
- Ø 130 x 70 mm diagnostic
- Ø 50 x 50 mm

Unit dimensions

Height	1406–2206 mm
Weight	180 kg
Height adjustment range	800 mm
Width x depth installation	1,212 x 1,545 mm
	Wall mounting

Electrical connection

Mains voltage	200–240 VAC
Frequency	50/60 Hz
Rated power	170 W, 2.2 kVA max.

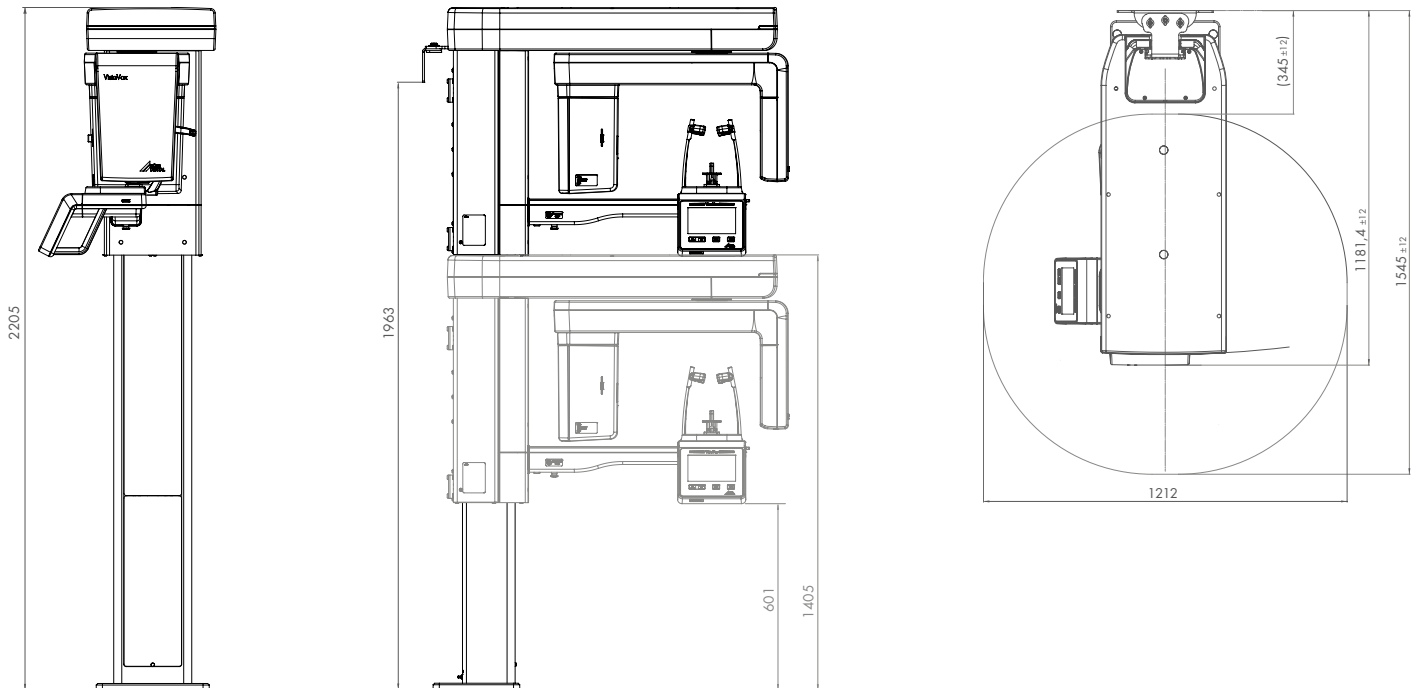

* Image acquisition programs for children: for children and adolescents from the age of 7.

VistaVox S-Ceph

X-ray HV generator

Voltage, current	60–99 kV, 4–16 mA
Rated power	1.6 kW

Tube

Focal point	0.5 mm (IEC60336)
Total filtration	2.8 mm AL

Image detector

Type	CsI CMOS photodiode array	
Pixel size	49.5 µm	100 µm
Active sensor surface area	135.8 x 36.4 mm	259.2 x 15.6 mm

Magnification factor

2D images	1.26	1.15
-----------	------	------

Scan times

Scan times	From 2 to 18 secs.
Ceph programmes	Lateral head images in quick scan mode: 1.9 seconds (line scan)

Pano and Ceph programs

Pano image acquisition programs	17
Image acquisition programs for children*	4
Ceph image acquisition programs	6

3D volume

Ø 130 x 50 mm upper/lower/sinus
Ø 130 x 85 mm diagnostic
Ø 130 x 70 mm diagnostic
Ø 50 x 50 mm

Unit dimensions

Height	1406–2206 mm
Weight	202 kg
Height adjustment range	800 mm
Width x depth installation	1,941 x 1,615 mm Installation on a wall or standing on feet (optional foot with wall installation)

Electrical connection

Mains voltage	200–240 V AC
Frequency	50/60 Hz
Rated power	170 W, 2.2 kVA max.

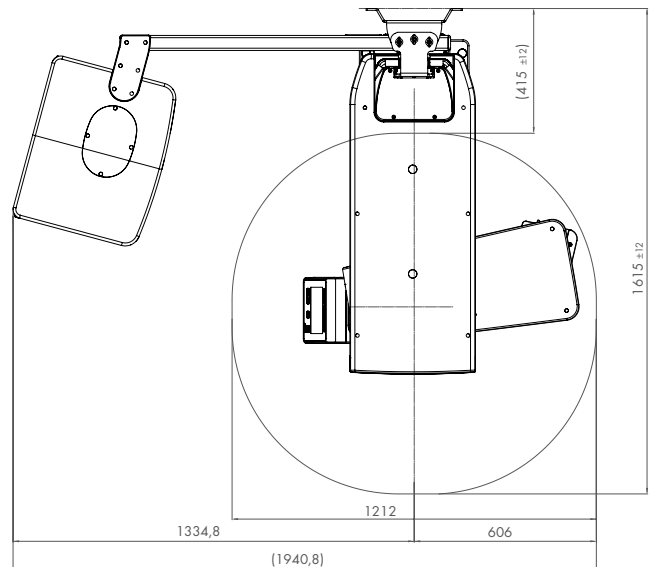
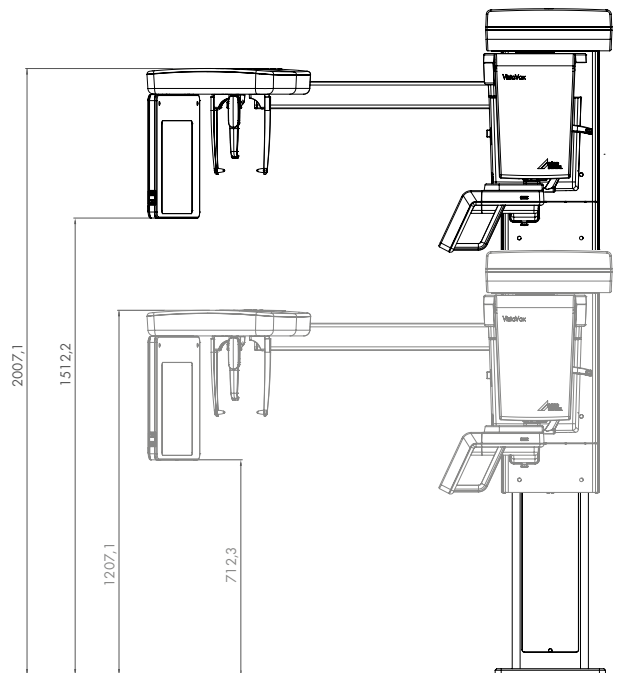

VistaVox S is manufactured using state-of-the-art technology at our Gechingen site in the Black Forest, Germany. This enables us to ensure the high quality and reliability of the device.



Want to know more?

» www.duerrdental.com



VistaScan

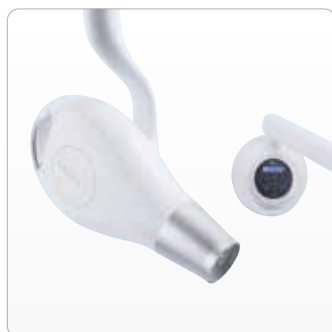

VistaIntra



VistaPano



VistaVox

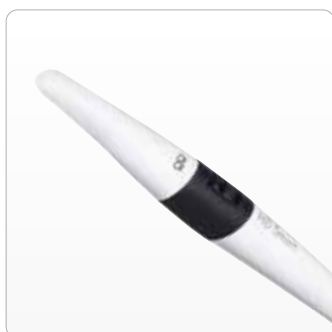

VistaCam

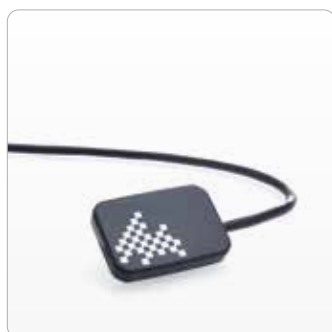

VistaRay



VistaSoft



Accessories



Scan the QR code
or call 1800 225 010 to contact your local A-dec dealer

